

BENEFITS

The NGC (Natural Gas Chromatograph) performs on-site gas analysis and heating value computation where current chromatograph technology has been either impractical or unaffordable. This truly "transmitter-like" GC takes up no more room on the pipeline than most multivariable transmitters. The fast analysis cycle and automatic setup features make installation and maintenance unusually easy. The state-of-the-art built-in 32 bit digital controller, the dual electronic carrier pressure regulators, oven-mounted sensors, and other low-noise electronics provide unparalleled sensitivity and months between calibrations.

- New design, more compact, more reliable, more precise
- Custody transfer/metrology quality GC for heating value and composition
- Lower cost to buy, install and operate

**STANDARD FEATURES**

- Modular design includes:
 - ◇ Modular software – application based plug in software modules
 - ◇ Manifold module (internal tubing now replaced by manifold)
 - ◇ Analysis section contains stream selection solenoids, pressure regulation, 32 bit digital detector electronics and a dual-train chromatograph in a single, replaceable module
 - ◇ 32 bit digital, low-power controlling electronics, using Windows CE® (internal to GC unit)
- Microsoft® Windows® 2000 or XP based man-machine interface software (PCCU 32)
- Lithium battery-backed RAM
- Two remote serial digital communications ports; one local port
- Comprehensive diagnostics and wizards available to users

- Three-level security for user access control
- Audit-quality historical data; date and time stamped
- Auto-start cycle automatically:
 - ◇ Stabilizes oven temperature
 - ◇ Confirms modules' functions
 - ◇ Sets valve operation times
 - ◇ Locates natural gas components
 - ◇ Sets carrier gas pressures
 - ◇ Gates natural gas components
 - ◇ Validates/calibrates
 - ◇ Returns to pipeline streams
- Operational alarms and events, time, and data stamped in a log.
- Memory: up to 2.052 GB
- Detectors - constant temperature, glass encapsulated thermister beads for rugged service and long life. Will not burn out on loss of carrier.
- Dual 10 port valves have no moving metal parts.
- Low utility usage - low-power, low-carrier, no instrument air required
- On demand or scheduled automatic calibration and diagnostics
- Calibration options:
 - ◇ Exponential
 - ◇ Linear
 - ◇ Multi-point (6 points)

STANDARD OPTIONS

- Sample Conditioning System
- On board digital 1/4 VGA display with multiple screen access
- USB (Host and Client) and Ethernet ports
- Calculation packages (eg, V.O.S., HCDP, Etc.)
- SD memory cards (up to 2 GB)
- Feed-Through heater
- C₇₊, C₉₊ analysis
- Optional: AI/DI, AO/DO per customer requirements
- Optional: 24 hour temperature testing

Natural Gas Chromatograph (NGC) 8206

DESCRIPTION

A natural gas sample is extracted from a flowing pipeline, transported to the analyzer, processed for particle removal and phase integrity, injected onto the chromatographic columns where component separation and peak detection occurs.

The NGC 8206 analyzes each sample utilizing established chromatographic techniques. The resulting information consists of mole percent values for the following:

“Air” (Contains N₂, Ar, CO and O₂ but not CO₂)
C1 CO₂ C2 C3 IC4 NC4
NeoC5 IC5 NC5 C6+

Using process chromatographic techniques, the columns are back flushed so that the NGC 8206 measures a C6+ peak. Users may input the results of a comprehensive lab analysis that reflects the split or ratio of C6 through C10 components. This ratio can be used in subsequent analysis and energy calculations. Calculated values include:

- Gas compressibility per AGA 8
- Real Relative Density (Specific Gravity)
- Btu/CV Value
- GPM (gallons of liquid per thousand cubic ft)
- Wobbe Index
- Methane Number
- Optional calculations can include: AGA 10 speed of sound, Hydrocarbon Dew Point

The portioned sample is then vented with the carrier gas and results are stored in memory and communicated to other devices as needed. All of these values as well as composition are available on various modbus communication protocols.

INSTALLATION

The NGC 8206 is a weatherproof device designed for installation “on the pipe” near to the sampling point. This means it is acceptable to mount outside - in a temperature range of 0°F to 131°F (-18°C to 55°C) [provides reliable operation for -20°F to 131°F (-29°C to 55°C) with low temperature option] onto a pipeline with 2" to 12" pipe sizes or with an optional pole mount configuration. A cold weather enclosure is also available if ambient conditions are below either the sampled gas dew point or the operational specifications of the unit.

SAMPLE SYSTEM

The integral stream selector for the NGC 8206 allows sampling up to four (4) different natural gas streams. Up to two of these sample streams can be designated as the “calibration/validation sample”. Optional sample conditioning modules are available to address natural gas streams that need additional filtering and “speed loops” to reduce sample transport lag times.

SAMPLE PROBE

Totalflow recommends the use of a sample probe to obtain a representative sample of the flowing gas stream. Two brands of optional sample probes are available from Totalflow and are specifically designed to require no power and avoid sample probe regulator icing. An electrically heated probe is also available.

OPERATOR INTERFACE

Functional setup and operation of the NGC 8206 is accomplished by using a graphical user's interface software package called PCCU 32 (supplied with each unit) operating on a laptop PC in a Microsoft® Windows® 2000 or XP environment. The “Windows®” utilities, combined with software designed specifically for the NGC 8206, provide a powerful tool for operations, diagnostics, and downstream data handling. The PC can be directly connected to the NGC 8206 via an RS-232, USB, or Ethernet connection, or indirectly by remote telemetry (phone modem, radio, cell phone, satellite, etc.). The user is prompted through push-buttons, drop-down boxes, wizards, and dialog boxes for setup, operations, data collection and monitoring.

In addition, the unit has an optional ¼ VGA interactive display screen allowing the user access to basic analysis data. The user can also accomplish most of the “operator” functions from the front panel display with out the use of a laptop PC. The “Run-Hold-Calibrate” functions can be done via a magnet interface through the explosion proof glass in the display.

MAINTENANCE

The NGC 8206 was designed from the ground up to be maintained by personnel with little or no prior knowledge of Gas Chromatography. Both hardware and software are designed to provide low maintenance through easily replaceable



Natural Gas Chromatograph (NGC) 8206

electro-mechanical modules such as:

- NGC Termination Panel
- NGC Analytical Module, an easily removable Chromatograph subassembly, containing; NGC Manifold, Stream Selector Solenoid Valves, GC module, Dual Electronic Carrier Pressure Regulator Valves, Chromatograph Pilot Valve, and the NGC Analytical Processor.
- NGC Feed-Through (heater optional)
- Sample Conditioning Module (SCM)
- NGC Controller, (32 bit Processor)
- NGC ¼ VGA Display (Optional)

Other Maintenance Support Features:

- Intuitive Local Operator Interface (PCCU 32) running Microsoft® Windows® 2000 or XP
- Diagnostic software and wizards for maintenance
- Diagnostic file output system for e-mail support
- Digitized detector output (chromatogram) to PCCU 32
- Remote or local operation of PCCU 32
- Quick Start guide, Start up manual and Start up video

HISTORICAL DATA

The NGC 8206 is designed to retain historical data. This data can be used for custody transfer needs, verify transmitter operation over time, and provide a limited data backup for communication link reliability.

The user is allowed to configure the period of the data retained by the NGC 8206 via the Operator Interface.

The default¹ memory configuration provides the most recent 480 analysis cycles containing:

- Normalized components
- Un-normalized components
- Ideal Btu/CV
- Real Btu (wet and dry) / CV (superior and inferior)
- Relative Density (Specific Gravity)
- Density
- GPM
- Wobbe index
- Alarms

Stream averages for the (default¹) 840 last hours, 35 last days and the most recent last month analyses.

Operational Parameters for the (default¹) last 480 cycles (Diagnostics Report):

- Selected peak times
- Selected peak areas
- Ideal Btu/CV
- Carrier regulator pressure
- Oven temperature
- Ambient temperature
- Sample pressure
- Detector noise values
- Detector balance values

Audit logs (default¹)

- Last 480 alarms
- Last 480 events

Data retained by the NGC 8206 can be collected via a remote communication link or by the laptop PC local operator interface PCCU 32.

AVAILABLE ACCESSORIES

- 120/240 VAC to 12VDC GP and Exp power supplies
- Pole or pipeline mounting kits
- Cold weather enclosure (also available in pipe mount configuration)
- Cold weather thermal jacket (future)
- Modular Sample System Conditioner options for
 - ◇ Non-pipeline quality natural gas sample
 - ◇ Sample transport lag-time needs
- Probes
 - ◇ Temperature compensating fixed
 - ◇ Temperature compensating retractable
 - ◇ Liquid rejection
 - ◇ Electrically heated, retractable
- Regulators (carrier and calibration blend)
- Start-up calibration/validation gas sample (±2% blend)
- Carrier Gas: 99.995% pure helium (chromatographic grade)
- SD memory card
- Export crating
- Tool kit
- Welker liquid shut-offs
- Various maintenance kits
- Customer Factory Acceptance Test (FAT)

(Default¹) The default memory configuration will provide for the data storage above. User may reallocate the memory that is available.



Natural Gas Chromatograph (NGC) 8206

SPECIFICATIONS

- Designed for Pipeline-Quality Natural Gas. 800 to 1500 Btu per standard cubic foot (29.8 to 55.9 megajoules/meter³) with less than 100 PPM H₂S
- Calculations Per: GPA 2172-96 (Z by AGA 8 or single virial summation) and 2145-03, ISO 6976-95; ISO 12213 (by AGA8); in the future

- ASTM D 3588, GOST or ISO mass
- Environmental Temperature
- Meet or exceeds GPA 2261-99 for linearity
- Four stream capability. Manual calibration required with 4 sample streams.
- Single auto calibration stream and 3 sample streams, or 2 auto calibration streams and 2 sample streams.

Specifications	
Dimensions	6.75" wide × 16.00" long × 9.00" tall (17.1 cm × 40.6 cm × 22.9 cm)
Weight	Approximately: 28 lb. (12.7 Kg) Shipping Weight: 47 lb. (21.3 Kg)
Weatherproof Construction	NEMA/Type 4X/IP 56, aluminum alloy with white polyester powder coating.
Power Consumption	Nominal operation @ 0°F (-18°C) = 7 Watts; (650 mA) Start up @ less than 3 amps (45 Watts @ 15 VDC)
Carrier Gas	Helium (consumption rate <20 cc/minute during analysis cycle)
Analysis Time	Approximately five (5) minutes; cycles may be scheduled by user
Repeatability	±0.125 Btu @ 1,000 Btu (±0.0125%) at ambient ±0.25 Btu @ 1,000 Btu (±0.025%) over temperature range of 0°F to 131°F (-18°C to 55°C)
Environment Temperature	Normal Operation: 0°F to +131°F (-18°C to 55°C) Temperature Range (Storage): -22°F to +140°F (-30°C to 60°C) With Cold Weather Enclosure: -40°F to +131°F (-40°C to 55°C)
Moisture	95% Relative Humidity Non-Condensing
Supply Voltage	10.5 to 16 volts DC. Optional: 21 to 28 VDC
Certifications	NEC & CEC Class I, Div. 1, Groups B, C, and D, T6 CFR 47, Part 15 IECEX Exd IIB + H2 T6; Class I Zone 1 INMETRO Exd 11B + H2 T6; Class 1 Zone 1 CE - ATEX  II 2G : Ex d, IIB+H ₂ T6; Class I, Zone 1 - EMC - EMI/RFI: - EN 55022, EN 61000-6-1, EN 61000-4-2, 4-3, 4-4, 4-6, 4-8 - CISPR 22-2004
Miscellaneous Type Approvals	Industry Canada NMI (Netherlands) BRML (Romania) China Weight & Measures
Communications supported	Two serial digital ports, software selectable for RS232, RS485, or RS422 One Man-Machine Interface (RS232 or USB) Optional USB hub (host and client) and Ethernet Ports
Protocols supported	Totalflow Remote / Local MMI Totalflow / TCP Modbus / TCP Server Modbus / TCP Client Modbus ASCII or RTU (Modicon, WordSwap, or Danalyzer) DSFG (future)
Memory	Up to a total 2.052 GB of RAM: CPU RAM Memory 20 MB Nand Flash 32 MB Data Storage 128 MB - 2 GB



Natural Gas Chromatograph (NGC) 8206

Installation Dimensions

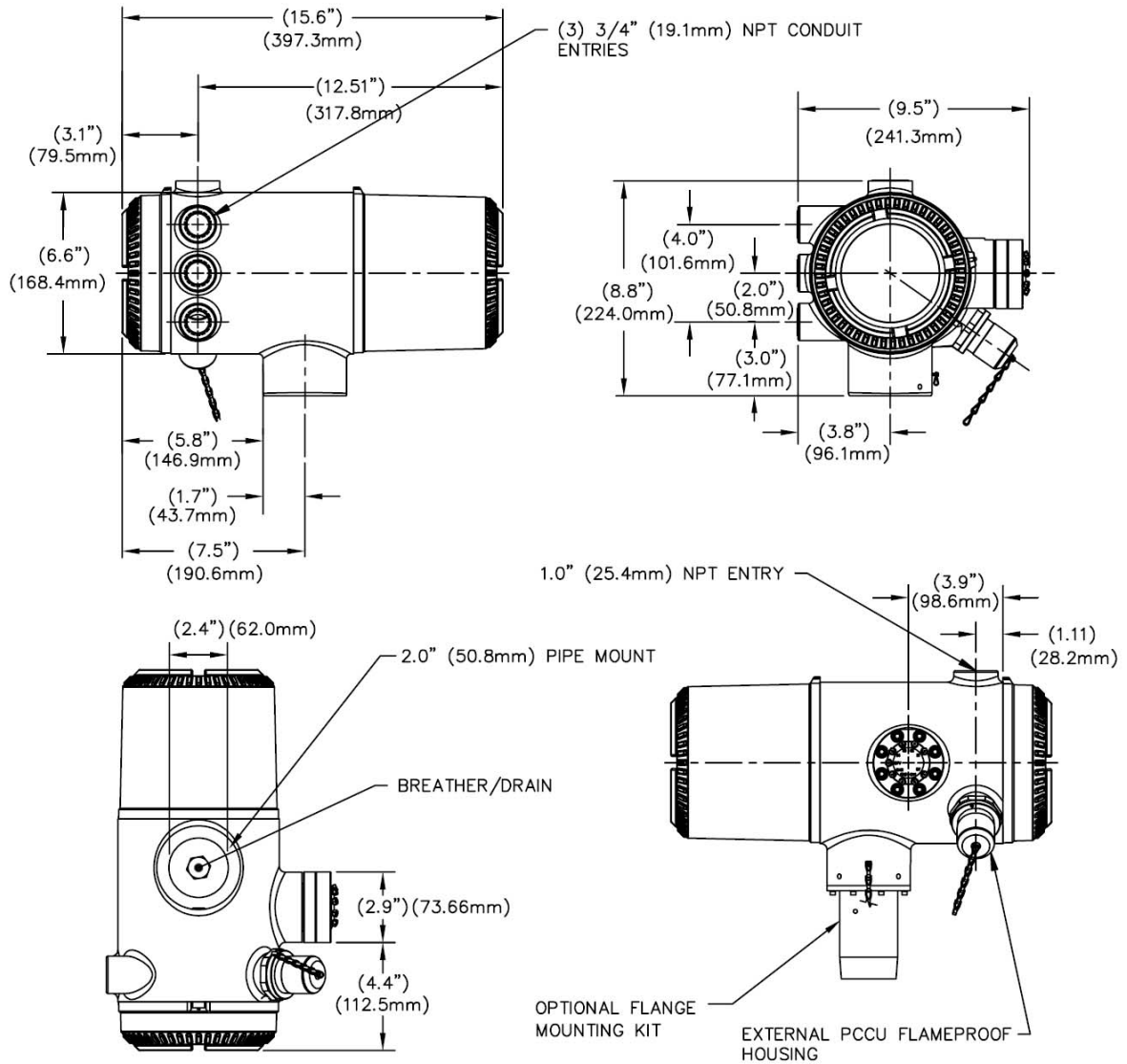

Australasia Official Representative of ABB Analysers

***ABB Analysers Sales and Services
By
POGC Sensor Technology - HMA Group***

Website: www.hmagroup.com.au

**Contact: 13 Sirius Road, Lane Cove NSW 2066 Australia
Tel: +61 (0)2 9428 7300 Fax: +61 (0)2 9428 7399
Email: sydney@hmagroup.com.au**