

Tunnel Atmosphere Monitoring

TunnelCraft III Air Quality Monitor for CO, NO & Visibility

Low-Cost Precision Sensors

The Air Quality Monitor (AQM) uses both infrared and visible light channels to measure carbon monoxide, nitric oxide and visibility in a single compact instrument.

The AQM consists of a transceiver that projects visible and infrared beams to a reflector unit mounted 3m away. The reflected light is received by the transceiver and the specific absorption is measured to determine the visibility dimming coefficient, carbon monoxide and nitric oxide concentrations within the path of the beams.

CO and NO concentrations are derived using gas cell correlation infrared absorption technology, to provide accurate, low-drift measurements.

Visibility is measured using visible light transmission from a high-power modulated LED, enabling high accuracy measurements to be obtained without interference from other light sources within the tunnel.

- multi-channel measurement technology to measure CO, NO & visibility in one compact sensor
- high resolution measurement of visibility
- designed to withstand the harshest of tunnel environments
- precision of 1ppm for CO, 2ppm for NO and 0.0002m⁻¹ for visibility
- routine maintenance limited to annual cleaning of optical surfaces
- modular construction ensures simple installation and cabling
- IP67 ingress protection rating EN60529
- measurement totally unaffected by strong light sources



No.1 in Tunnel Atmosphere Monitoring



Overall Unit Dimensions

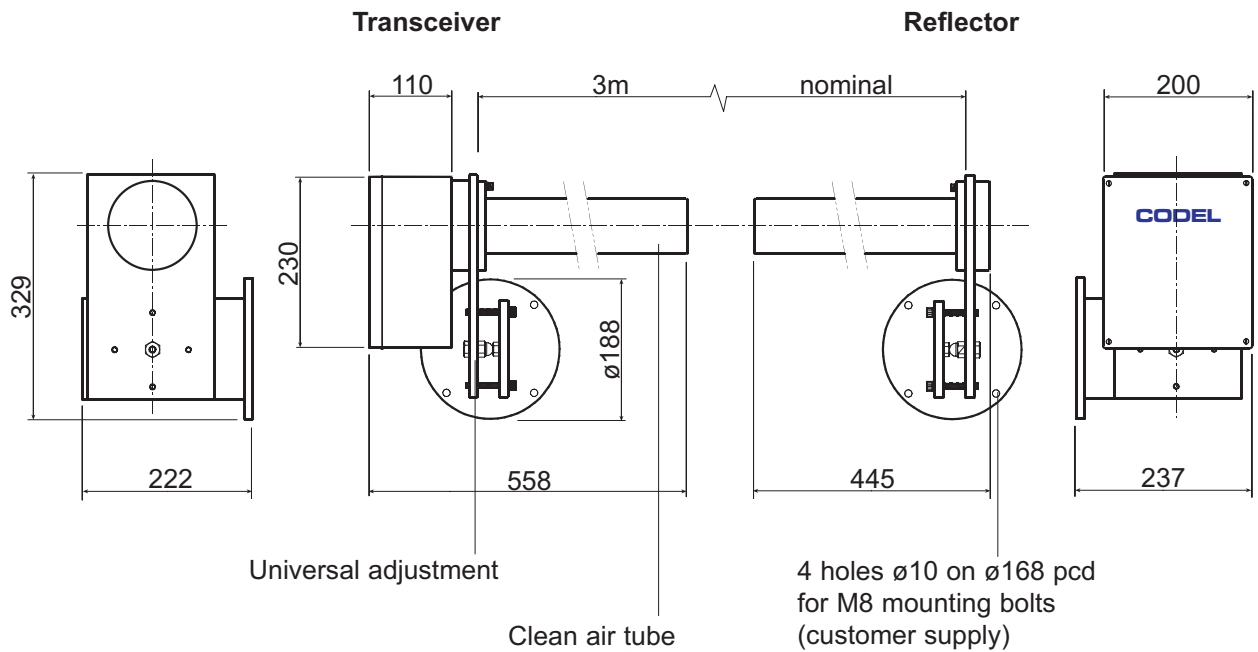

Specification

AirQuality Monitor

Measurement: up to three channels for CO, NO,
Channels & visibility

Measurement: 3m (6m folded beam)
Path

Measurement: CO : 0 - 100ppm
Range NO : 0 - 30ppm
(typical) visibility : $0-15 \times 10^{-3} \text{ m}^{-1}$
other output ranges field selectable

Accuracy : CO : $\pm 1 \text{ ppm}$
NO : $\pm 2 \text{ ppm}$
visibility : $\pm 0.2 \times 10^{-3} \text{ m}^{-1}$

Power : 12V DC, 20VA from separate
Requirement power supply unit

Averaging : selectable 1 to 60 minutes
Time

Ambient : -20°C to $+50^{\circ}\text{C}$
Temperature

Construction

Housing : corrosion resistant epoxy coated
aluminium sealed to IP67

Communications & Outputs

Local : RS232 (optional RS485) serial
Comms. interface via plug & socket

Analogue : 3 x 4-20mA, max. load 500Ω

Logic : 3 x volt-free contacts SPCO, 0.25A
@ 125V AC, 1A @ 30V DC, 0.25A
@ 100V DC

Compliances

EMC : 89/336/EEC directive compliant

Low Voltage : 73/23/EEC directive compliant

CODEL International Ltd.
Station Building, Station Road
Bakewell, Derbyshire DE45 1GE
England

Tel: +44 (0) 1629 814 351
Fax: +44 (0) 8700 566 307
e-mail: codel@codel.co.uk
web site: www.codel.co.uk

Distributor :

