

Tunnel Atmosphere Monitoring

TunnelMaster Concept

TunnelMaster is a well-proven tunnel atmosphere monitoring system designed exclusively for road tunnel applications. It offers a family of monitors that provide all the essential measurements necessary to monitor the tunnel atmosphere :

- Visibility
- Carbon Monoxide
- Nitric Oxide
- Nitrogen Dioxide
- Air Flow and Direction

It achieves this with a modular design concept so that the user's precise monitoring requirements can be satisfied with a minimum number of components, minimum tunnel cabling and minimum installation costs. TunnelMaster also offers a variety of data outputs to enable simple acquisition of data.

Operating costs are held to an absolute minimum with sensors designed to operate with high data availability and minimal maintenance.

- automatic zero adjustment enables the highest accuracy and stability to be maintained
- designed to withstand the harshest of tunnel environments
- high measurement availability with almost maintenance-free operation
- modular construction and digital data transfer ensures simple installation and cabling
- flexible choice of analogue and digital interfaces
- low cost of ownership
- routine maintenance limited to annual cleaning of optical surfaces

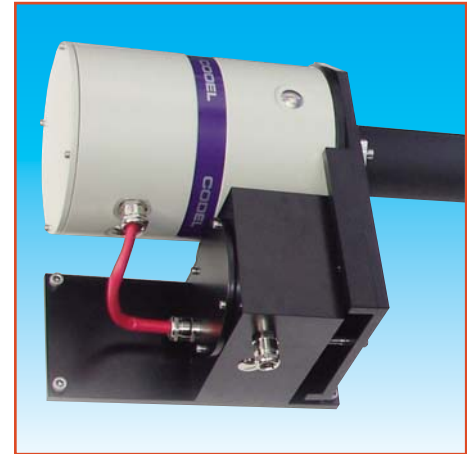
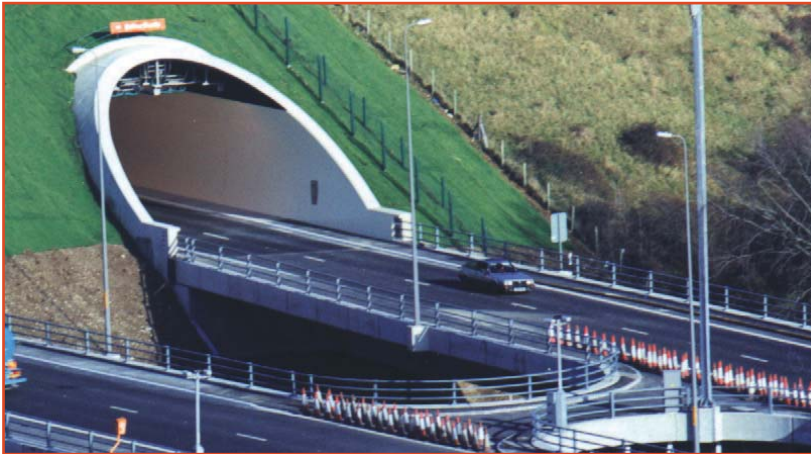

Total Solutions - Total Confidence



System Schematic

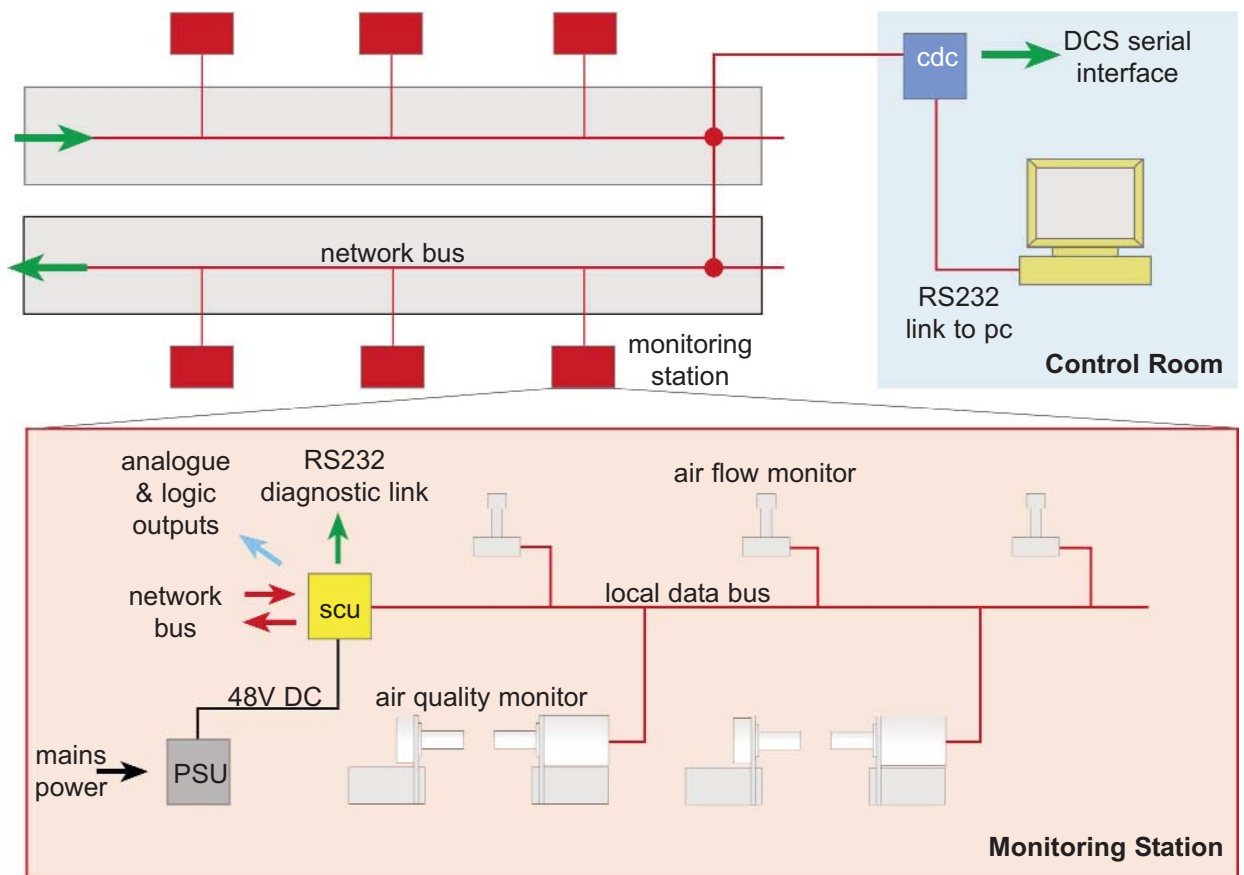

Specification

Monitoring Station

Measurement- CO, NO, NO₂ & visibility
Species

Outputs - 4-20mA analogue outputs, volt-free
contact relays

Network Data Bus - serial digital data link, 4800 baud
current loop, 4-wire data bus,
opto-isolated at SCUs

- distance up to 10km

- number of monitoring stations
up to 32

Power to Sensors - 48V DC via digital data bus

Central Data Control

Data Logging - by dedicated pc, 5-year data
retention

Data Presentation - by CODEL WinCom Windows 95,
98, NT based software

System Output - RS232 serial digital link supporting
MODBUS protocol for plant
computer/DCS link

Remote Comms. - full data access via modem

Compliances

EMC - 89/336/EEC directive compliant

Low Voltage - 73/23/EEC directive compliant

CODEL International Ltd.
Station Building, Station Road
Bakewell, Derbyshire DE45 1GE
England

Tel: +44 (0) 1629 814 351
Fax: +44 (0) 8700 566 307
e-mail: codel@codel.co.uk
web site: www.codel.co.uk

Distributor :

